



OSD 6

OSD 18

OSD 35

OSD 60

Westfalia Separator® dtype Separator

Technical Data | Type OSD 6-91-067 / OSD 18-91-067 / OSD 35-91-067 / OSD 60-91-067

The Westfalia Separator® dtype separator has been designed for the clarification and purification of mineral oils (e.g. lube oil, hydraulic oil). The self-cleaning centrifugal separator easily removes water and impurities keeping the oil continuously clean. Key benefits: longer equipment and oil service life, less operating costs, enhanced performance.

Materials of construction

Frame: Grey cast iron
 Hood: Silumin
 Main bowl parts: Stainless steel

Standard equipment

- 3-phase AC motor
- Rubber cushions with welding plates
- Flexible feed and discharge lines
- Flow indicator
- Pre-set valve with connectors
- Pressure switch clean oil discharge
- Valve block for operating, filling and displacement water
- Set of commissioning parts

Additional equipment (at extra cost)

- Motor control
- Control unit for automatic operation
- Pump
- Pre-strainer and pre-heater
- Set of tools
- Vibro control
- Product temperature monitoring
- Each separator is also available as ready-to-connect compact unit, including accessories

Technical Data OSD ..-91-067

Operating principles and constructional features

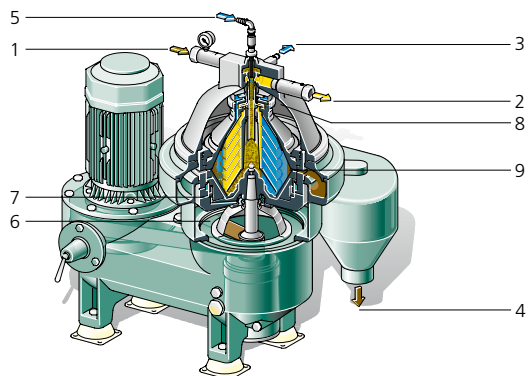

- 1 Product feed
- 2 Discharge light liquid phase
- 3 Discharge heavy liquid phase
- 4 Sludge discharge
- 5 Displacement water
- 6 Operating water feed
- 7 Operating water discharge
- 8 Double centripetal pump
- 9 Solids holding space

The Westfalia Separator® dtype separator is equipped with a Westfalia Separator® softstream inlet system for gentle product treatment. This results in optimum separating efficiency and higher specific capacities. The patented Westfalia Separator® hydrostop system of the Westfalia Separator® dtype separator enables controlled bowl ejections to be carried out at full operating speed.

The Westfalia Separator® dtype separator has a self cleaning bowl, optionally equipped for the clarification of liquids or the separation of liquid mixtures with simultaneous solids removal. The product (1) is fed in through a system of closed lines. The separated light (2) and heavy liquid phase (3) are pressure discharged via centripetal pump (8). The centrifuge operates with regulating rings for the heavy phase.

Applications

- Automotive industry
- Metalworking industry
- Power stations
- Oilfield industry
- Shipping industry
- Steel rolling mills

Technical data	OSD 6	OSD 18	OSD 35	OSD 60
Bowl				
Speed	12,000 rpm	11,500 rpm	8200 rpm	6800 rpm
Volume	1.5 l	3 l	8 l	21 l
Solids holding space	0.9 l	1.5 l	4 l	11 l
3-phase AC motor				
Rating (50 Hz)	up to 4 kW	up to 7.5 kW	up to 18.5 kW	up to 30 kW
Rating (60 Hz)	up to 4.6 kW	up to 8.6 kW	up to 21 kW	up to 35 kW
Speed at 50 Hz	3000 rpm	3000 rpm	3000 rpm	1500 rpm
Speed at 60 Hz	3600 rpm	3600 rpm	3600 rpm	1800 rpm
Design	IM V1	IM V1	IM V1	IM V1
Type of enclosure	IP 55	IP 55	IP 55	IP 55
Centripetal pump	1 bar	1 – 2 bar	2 bar	2 bar
Weight and shipping data				
Separator with bowl and motor	200 kg	310 kg	1050 kg	1600 kg
Bowl	42 kg	72 kg	190 kg	360 kg
Case dimensions (LxWxH)	1280x700x1030 mm	1300x870x1030 mm	1800x1000x1400 mm	1800x1050x1600 mm
Shipping volume	0.92 m ³	1.17 m ³	2.5 m ³	3.0 m ³
Dimensions				
A	753 mm	908 mm	1185 mm	1515 mm
B	540 mm	583 mm	752 mm	865 mm
C	990 mm	1097 mm	1382 mm	1606 mm



GEA Mechanical Equipment

GEA Westfalia Separator

Werner-Habig-Straße 1 · 59302 Oelde (Germany)

Phone +49 2522 77-0 · Fax +49 2522 77-1778

www.westfalia-separator.com